

# TERANO 40

## User & Installation Manual



### Introduction

TERANO series are IP68 in-ground linear luminaires offered by Electron SA for indoor and outdoor applications. They are most used for wall washing and surfaces illumination, but they can also cover other lighting needs.

Terano is available in lengths of 25cm, 50cm, 100cm, 150cm & 200cm, with two voltage options, Cost Effective and Constant Power models at 24VDC and High Efficient models from 24VDC up to 48VDC..

At ELECTRON we value each and every customer, and we want to thank you for your purchase of TERANO. We believe that this manual will serve as a useful guide and resource for you, and we look forward to hearing your feedback.

Please note that before using this equipment it is mandatory, for safety reasons and for the proper use of TERANO, to carefully read this user manual.



Reproduction of all or part of this user manual, in any form, is not allowed without prior written authorization from Electron SA. Electron SA reserves the right to make any changes in this user manual without any prior notice

## General notes and precautions.

### Before first use.

- Make sure to read thoroughly all the instructions before using the TERANO 40.
- In case that you do not understand any of the instructions or have any doubt for the installation or operation of the TERANO 40, please consult your supplier.
- The installation of TERANO 40 must be done by a specialized technician.

### Installation.

- TERANO 40 must not be installed, in any case, on flammable areas.
- Do not install TERANO 40 near any kind of heating source.
- All connections and wiring of TERANO 40 are IP 68 graded  
It is the installer's responsibility to ensure that all connections are properly executed in order to maintain that IP grade.
- Make sure that the power supply is turned off during the installation procedure.



### Mechanical.

- Make sure that TERANO 40 is properly installed, safely mounted and connected.
- When needed, the replacement of the front glass and lenses must be done by using authentic spare parts only and from authorized technicians.

### Electrical.

- The luminaire must be connected only by a qualified electrician.
- The supply input of multichannel TERANO 40 models (RGBW, Tunable white) is common anode and the appropriate power supply and controller should be used.
- Dimming can be accomplished by PWM (up to 4kHz) on power supply input.
- TERANO are class III devices.
- Disconnect the power supply for any service.

### General.

- Do not look directly to the TERANO'S light source when it's turned on.
- Do not try to fix any damage or malfunction, by opening the TERANO. This must be done by an experienced and specialized technician of your supplier.
- TERANO should be cleaned only with a soft cloth and water.
- The manufacturer is not responsible for any injury or damage that will occur from the improper installation or use of the product.
- The safety of this fixture is guaranteed only if you comply with the following instructions.
- Make sure that all the local laws and regulations are followed during the installation procedure.
- Remember to conserve these instructions in a safe place.
- At the end of its lifetime TERANO must be delivered in a special waste collection center. The improper disposal can cause damages for the environment and poses dangers for the human health.
- In case that the Terano series will be installed immersed in water, make sure that the depth of 3m will not be exceeded.

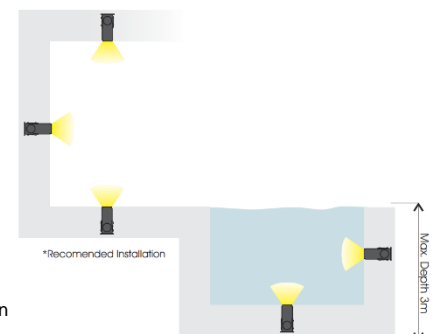
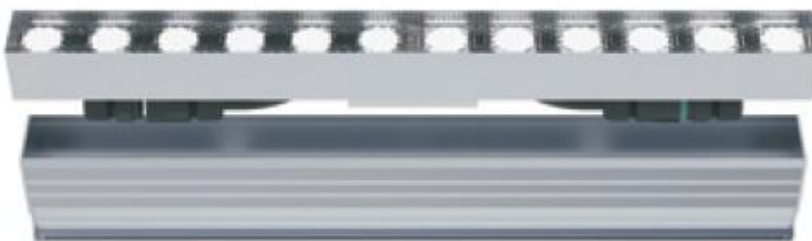

Physical Information

Model	Luminaire Length	Mounting Box Length	Luminaire Width	Mounting Box Width	Weight
TERANO 40	250 mm	254 mm	40	45	1,00kg
	500 mm	504 mm			2,00kg
	1000 mm	1004 mm			4,00kg
	1500 mm	1504 mm			6,00kg
	2000 mm	2004 mm			8,00kg

Table 1

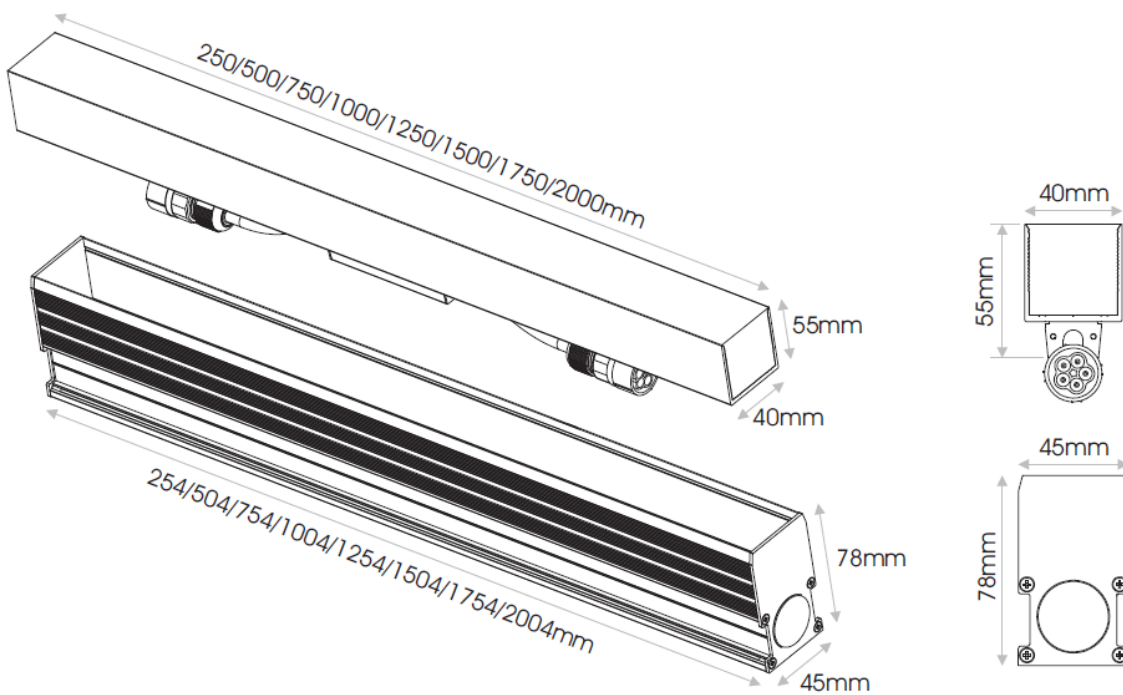

## Installation.

Before starting the installation, please read the section “General notes and precautions”.

Mount the installation box in the desired area, the area has to be level and uniform.

**ATTENTION:** Make sure that there is an appropriate drainage system, to avoid accumulation of standing water.

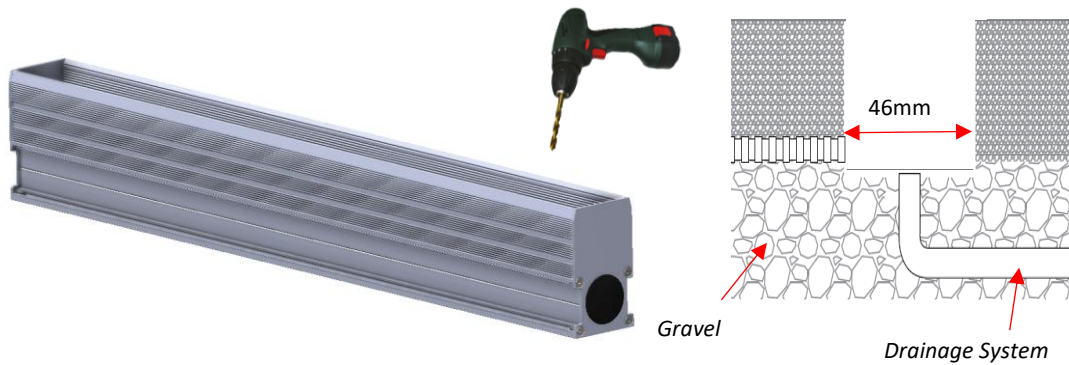

In order to mount more than one Terano's mounting boxes in-line, the end caps must be removed (a) and PRH.108 alignment kit (b) should be used.

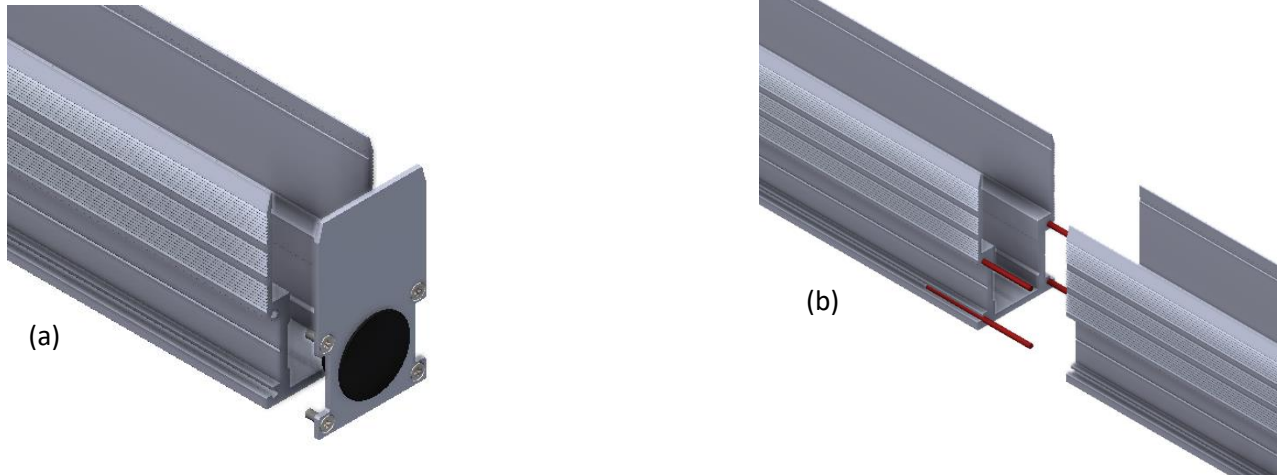

For the proper installation of the mounting boxes the installer must leave the appropriate gap between each mounting box:

- Terano 25cm: 0.25mm
- Terano 50cm-75cm: 0.50mm
- Terano 100cm-150cm: 1.00mm
- Terano 175cm-200cm: 1.25mm

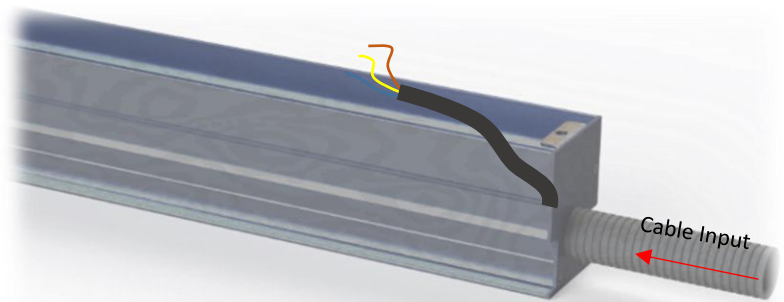

Remove the protecting plug and install an electrical tube in the pre-arranged position.

Pass all the cables through the electrical tubes prior to the concrete pouring.

**Installation.**

The installer must make sure that the concrete will not enter the mounting box or other components. The usage of painter tape to fill any gaps is recommended **(a)**. With the mounting box firmly secured and all the electrical tubes and cables arranged then the aluminum installation aid profile can be temporarily installed **(b)**, and the cement can be poured, once the cement is set then the aluminum must be removed.

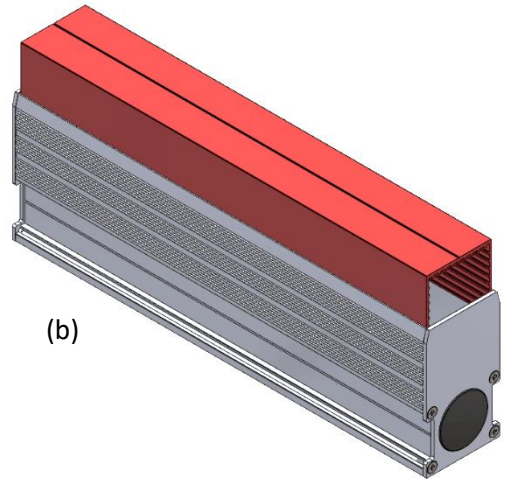
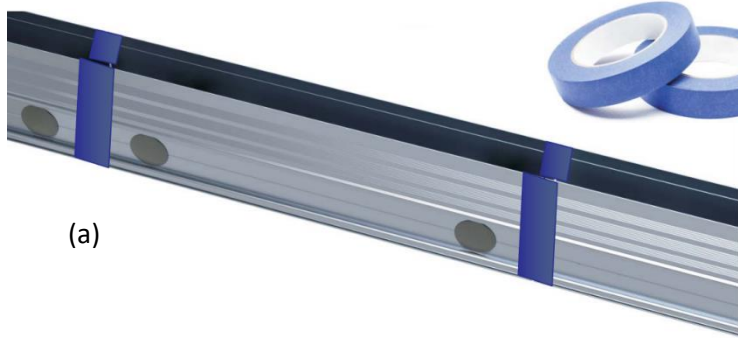

**Cables and power connector's description.**

TERANO 40 is delivered with input power connector as standard.

Each connector pole has a numerical description that must match the numerical description of the cable.

Pins layout position	Cable's Numerical Description
<b>Monochromatic Model:</b>	
Terminal 1: Positive (+)	Wire No1
Terminal 2: Negative (-)	Wire No2
<b>Tunable White Model</b>	
Terminal 1: Common (+)	Wire No1
Terminal 2: Warm (-)	Wire No2
Terminal 3: Cool (-)	Wire No3
<b>RGBW Model</b>	
Terminal 1: Common (+)	Wire No1
Terminal 2: Red (-)	Wire No2
Terminal 3: Green (-)	Wire No3
Terminal 4: Blue (-)	Wire No4
Terminal 5: White (-)	Wire No5

Table 2

The maximum / minimum cross section wire that can be connected to the terminals are the following:

Model	Min / Max Cross Section
Monochromatic	2 x 2.5mm <sup>2</sup> / 2 x 4mm <sup>2</sup>
Tunable White	3 x 1.5mm <sup>2</sup> / 3 x 4mm <sup>2</sup>
RGBW	5 x 1.5mm <sup>2</sup> / 5 x 1.5mm <sup>2</sup>

Table 3



## Power Supply.

- The TERANO 40 Series is available with two voltage options, **24VDC and 24~48VDC**, please check the label of the fixture, in order to verify the voltage.
- In Tunable white and RGBW models the positive pole is common for all channels. Thus, the controller or power supply that is going to be used for these models **must be Common Anode**.
- Dimming can be done by PWM (Pulse Width Modulation) from 100Hz up to 4kHz.
- During the installation of TERANO should not be supplied with voltage.

## Electrical Connection



(a)

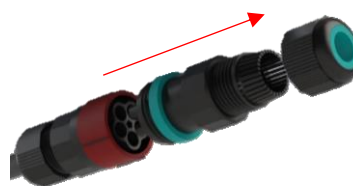

(b)

Remove the cable connector from the luminaire, by turning counterclockwise, the part marked as red. **(a)**, once removed then proceed with the disassembly of the unplugged connector **(b)**

Prepare the cable, that is going to be used.

Cable Diameter  $\varnothing$  7.00~12.00mm  
Insulator removal **(X)**: 20mm  
Peeling of the conductor **(Y)**: 6,00mm



Insert the individual conductors into the connector terminal, make sure that all the cables are installed and secured correctly.



**Attention:** Refer to Table 2 for making the connections correctly!

When all the wiring is done then the luminaire can be placed into the mounting box.

Connect the first TERANO 40 module to the power supply cable as shown below (a), if more than one luminaire must be installed in the same line (in-out) then the extension cable and IP68 connectors must be used (b) (refer to the catalog page). For the more information about the maximum length that can be achieved, refer to the **TABLE 5**.

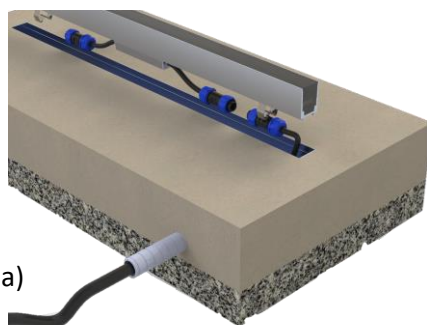

(a)

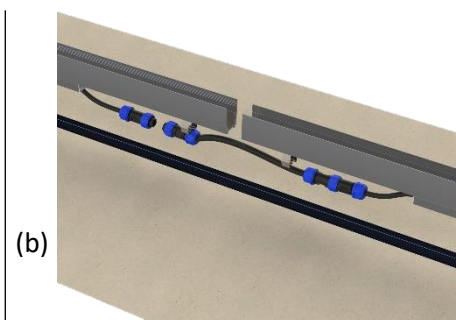

(b)

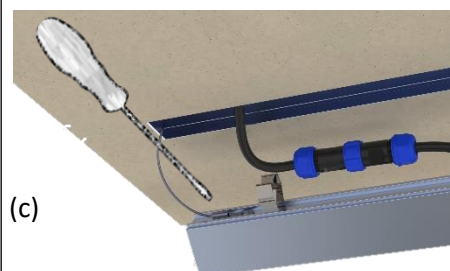

(c)

When Terano is placed in the ceiling or in the wall, then the safety wire be attached. Place the light fixture to the side and connect the safety wire rope. **(c)**

## Technical specifications.

Length.	25cm, 50cm, 100cm, 150cm, 200cm
LEDs.	Diffused lighting /Samsung LED. Directional lighting / Samsung LED.
LED / Lenses quantity.	6 @25cm, 12 @50cm, 24 @100cm, 36@150cm, 48@200cm (for directional lighting).
Lenses.	Φ23mm (PMMA).
Pitch size.	25cm, 50cm, 100cm, 150cm, 200cm: 41,65mm. (pitch maintained between luminaires)
Beam angle.	Monochromatic: 15, 25, 40, 10x30 & 15x45 degrees. Tunable white(2in1), RGBW(4in1): 12, 25, 15x30 & 12x50 degrees.
Dimming.	PWM 24VDC (Diffused models/ STD DR/HECP DR ) / PWM 24-48VDC (HE DR).
PWM Range.	0.1kHz – 4kHz.
Ambient temperature.	-25°C / +50°C.
IP rating.	IP68
Power connector.	IP68 2,3 or 5 poles depending on the model.
Connectors.	PA66 NYLON.
IK rate.	IK10.
Protective cover.	Tri- component polyurethane.
Main body.	Natural anodized anticorodal aluminum EN AW-6060.
Walk Over.	Up to 500kg(5kN).
Maximum Static Load.	Up to 2000kg (20kN).
Input voltage.	24VDC. (Diffused models/STD DR/ HECP DR models) / 24-48VDC (HE DR models).
Input type.	Common anode (Valid only for multichannel models).
Power consumption. (±4%)	Diffused models 25cm, 50cm, 100cm, 150cm & 200cm : 10.5W, 21W , 42W, 63W & 84W. Directional models 25cm, 50cm, 100cm, 150cm & 200cm: 10W, 20W, 40W, 60W & 80W.
Compliance standards.	LVD Directive, EMC Directive.

Table 4

### Maximum power of TERANO 40 in daisy chain connection.

TERANO 40 models offer input - output cabling (available upon request) thus, daisy chain connection can be used. As a result, only the first luminaire has to be power supplied.

When daisy chain connection is in place, the power of each chain should not exceed the values shown in the table below.

TERANO 40	Maximum power in daisy chain (Diffused, Standard directional models & Constant Power Models).	Maximum power in daisy chain (High efficiency models) *.
Monochromatic 24VDC	Up to 360W	Up to 320W
Monochromatic 48VDC	Up to 720W	Up to 640W
TW & RGBW 24VDC	Up to 280W	Up to 240W
TW & RGBW 48VDC	Up to 560W	Up to 480W

Table 5

**\*The distance (D) from the power supply to the first fixture must not exceed 5m. For D>5m & D≤10m the maximum power of the daisy chain must be reduced by 30% or you must power supply the output of the last TERANO from the same power supply as well (supply both in & out of the daisy chain).**

### Note.

In daisy chains it is possible for the luminosity of the first TERANO to be different with luminosity of the last one (only in Diffused & Standard Directional Models). This happens because of the voltage drop in the power supply cable. To avoid this, you can also supply the output of the last TERANO from the same power supply.

The voltage drop only affects the luminosity of Diffused & Standard Directional Models. The luminosity of High Efficiency & Constant power Models is not affected by the voltage drop.

